

## Miniature Metal Bellows Coupling

with set screws

optional  
laserwelded  
optional full stainless  
steel version

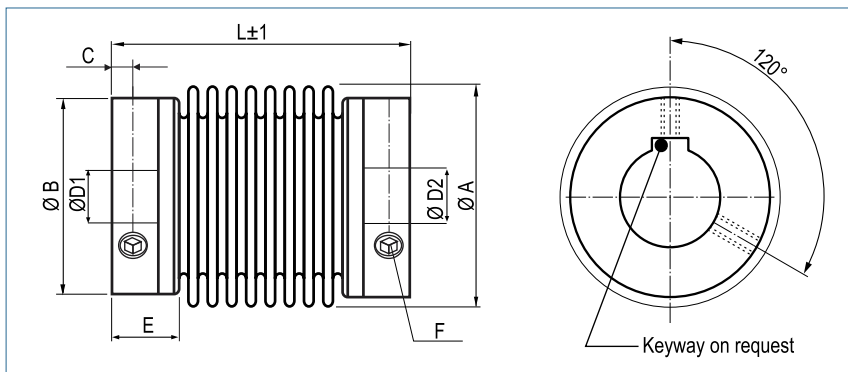

### Order Code

**KB1 / 45 - 40 - 10 - 18 - (S)**

Type / Size

Length  
L

ØD1  
(H7)

ØD2  
(H7)

Options

Size	Torque TKN (Nm)	Dimensions (mm)							Technical Data							
		L	Ø A	D1/D2	Ø B	C	E	F	Mass (g)	Moment of Inertia J (g cm <sup>2</sup> )	Spring Stiffness			Misalignment		
		Length	Outer Ø	Bore Sizes (H7) min-max	Hub Ø	Hub- length	Screw (ISO4029) TA (Nm)	torsional CT (Nm/rad)			radial CR (N/mm)	axial CA (N/mm)	radial ΔKr (mm)	axial ΔKa (mm)	angular ΔKw (°)	
05	0.05	14	6.5	1-3	6.5	1.5	4	1x M2 0.35	1	0.1	50	6	9	0.1	0.4	1
1	0.1	23	10	1-4	10	2	6	1x M3 0.5	3	0.45	65	10	14	0.12	0.2	1.2
5	0.5	19	15	3-8	13.5	2	6	1x M3 0.5	4	1.3	260	43	13	0.1	0.2	1
		4.5							1.5	200	18	10	0.15	0.3	1.5	
		5							1.6	160	9	8	0.2	0.4	2	
10	1	21	15	3-8	13.5	2	6	1x M3 0.5	5.5	1.8	510	74	27	0.1	0.2	1
		6							2	380	31	20	0.15	0.3	1.5	
		7							2.3	310	16	16	0.2	0.4	2	
15	1.5	26	19	3-12	19	3	8	2x M4	10	6	750	59	15	0.1	0.3	1.5
		30		8#				1.5	12	7.4	700	20	9	0.15	0.4	2
20	2	22	24	3-14	21.5	3	6	2x M4	11	9.2	1500	67	12	0.15	0.3	1.5
		13		12.6				1300	21	11	0.2	0.4	1.5			
		15		13.5				1050	11	9	0.25	0.5	2			
		32		10#				1.5	15	13.5	1050	11	9	0.25	0.5	2
45	4.5	40	32	6-19	29	4	12	2x M6	44	68	6500	168	32	0.1	0.3	1.5
		3		50				79	4200	41	20	0.2	0.5	2		
100	10	45	40	6-24	36	4	12	2x M6	60	150	8100	120	27	0.15	0.4	1.5
		3		79				210	6800	29	17	0.3	0.6	2		



<b>Speed</b>	max. 15000 min <sup>-1</sup>
<b>Material</b>	bellows - stainless steel, size 05: bronze hub - aluminium
<b>Hub</b>	bore tolerance: H7
<b>Temperature Range</b>	-30 °C ~ 120 °C
<b>Keyway</b>	optional acc. DIN 6885 biggest bore with keyway marked with a #